

SLIDE FACEPLATE OVER SCUPPER SLEEVE (SEE SECTION BELOW)

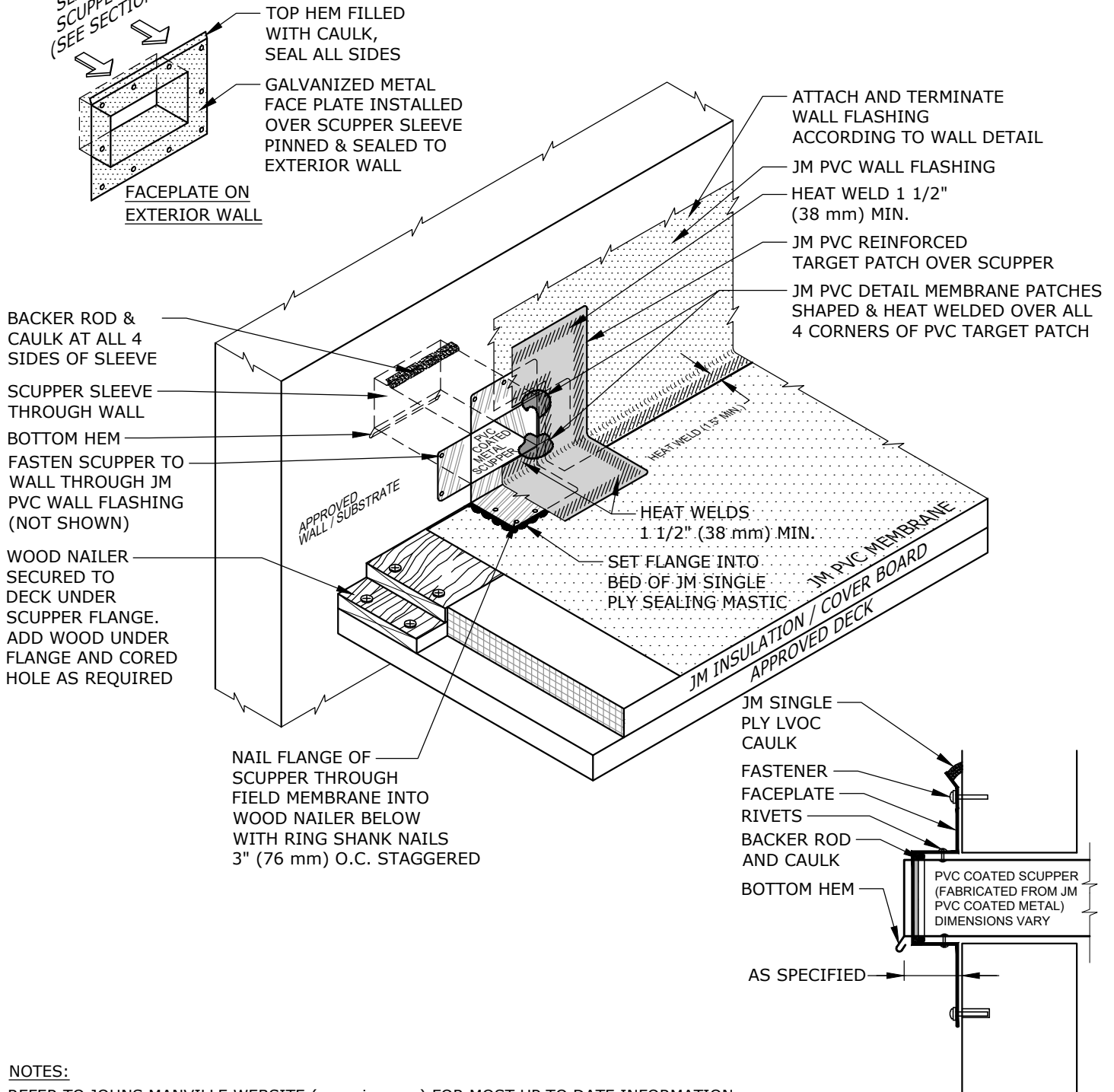

NAIL FLANGE OF SCUPPER THROUGH FIELD MEMBRANE INTO WOOD NAILER BELOW WITH RING SHANK NAILS 3" (76 mm) O.C. STAGGERED

SCUPPER SECTION AT EXTERIOR WALL

NOTES:

1. REFER TO JOHNS MANVILLE WEBSITE (www.jm.com) FOR MOST UP TO DATE INFORMATION.
2. PLEASE SEE SINGLE PLY FLASHING SPECIFICATIONS FOR A FULL DESCRIPTION OF INSTALLATION INSTRUCTIONS AND REQUIREMENTS WHICH ARE CONSIDERED A PART OF THIS DETAIL.
3. ANY CARPENTRY OR METAL WORK SHOULD BE DESIGNED AND CONSTRUCTED IN ACCORDANCE WITH LOCAL CODE REQUIREMENTS AND/OR PROJECT SPECIFICATIONS. THESE COMPONENTS SHOULD BE REVIEWED AND APPROVED BY A LICENSED DESIGN PROFESSIONAL.
4. JM PVC SEALANT IS OPTIONAL ON ALL CUT OR NON-ENCAPSULATED EDGES OF REINFORCED MEMBRANE. THIS INCLUDES FACTORY CUT MEMBRANE (SEE DETAIL P-MS-01).

DRAWING NO.

P-DV-06

DRAINS & VENTS

SCALE N.T.S. ISSUE DATE 09-11-24

MEMBRANE TYPE:
JM PVC

MAXIMUM GUARANTEE TERM:
30 YEAR

OVERFLOW SCUPPER

Johns Manville is a manufacturer of commercial roofing products and offers this general conceptual information to you as a courtesy for general educational purposes only. This complimentary assistance is not to be either used or relied upon by anyone as a substitute for professional engineering design and documentation required by any building code, contract, or applicable law. By accepting the general conceptual information, you agree it does not constitute any representations, endorsements of, or an assumption by Johns Manville of any duty or liability for either the adequacy of the design of a building, any of its components or the sufficiency of any construction.

